

[www.ciecanada.com](http://www.ciecanada.com)

Introducing

# HYDROPROTECT



## ANOTHER FIRST FOR RHODIUS!

Our innovation blocks moisture for a longer-lasting improved power.

Even when they are not in use: resin-bonded wheels age and their performance diminishes over time. During the storage of wheels, moisture penetrates between the bond matrix and the abrasive grains and weakens the bond. Rhodius has come up with a formula, HydroProtect that slows down the aging process by inhibiting the absorption of moisture for up to 10 months keeping the performance of the wheels almost constant after months of storage. This keeps the cutting performance at a permanently high level from the manufacture of the wheel through to the actual time of use.

**Products in the HydroProtect line are XT8 EXACT, XT35 CROSS, XT10, XT20, XT38, XT67 and XT24. Get that extra protection for your performance!**



# XTRA THIN CUTTING WHEELS

Full line catalogue available at [www.ciecanada.com](http://www.ciecanada.com)

**RHODIUS**<sup>®</sup>  
MADE IN GERMANY  
SINCE 1952



## XT67 / XTK67

PROLINE ●●●

**For steel or stainless steel**

- Long life & fast cutting times
- For thin walled tubes, profiles and sheet metal
- Reliable and precise
- Outstanding price-performance ratio

	TYPE 1 thickness x arbour 3/64" x 7/8"	TYPE 1 thickness x arbour 1/16" x 7/8"	TYPE 27 thickness x arbour .045" x 7/8"	BOX QTY
4 1/2"	A2180347	A2180350	A2180386	50
5"	A2180348	A2180351	A2180387	50
6"		A2180352	A2180384	25
7"		A2180353	A2180385	25

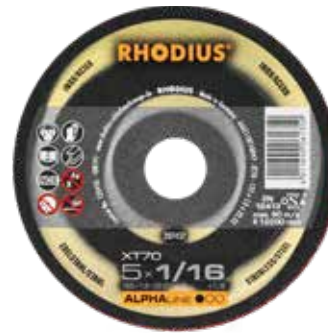

## XT70 / XTK70

ALPHALINE ●●●

**For steel or stainless steel**

- Low development of burrs
- High cutting speed
- Long lifetime
- Cool cut

	TYPE 1 thickness x arbour 1/16" x 7/8"	TYPE 27 thickness x arbour .045" x 7/8"	BOX QTY
4 1/2"	A2180590	A2180560	50
5"	A2180591	A2180561	50

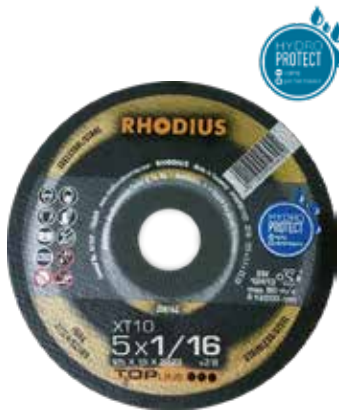

## XT10 / XTK10

TOP LINE ●●●

**For steel or stainless steel**

- Powerful disc
- Extremely accurate
- Fast cut with superior life

	TYPE 1 thickness x arbour 1/16" x 7/8"	TYPE 27 thickness x arbour .045" x 7/8"	BOX QTY
4 1/2"	A2180403	A2180413	50
5"	A2180404	A2180414	50
6"	A2180405	A2180415	25
7"	A2180406	A2180416	25



## XT24

TOP LINE ●●●

**For aluminum**

- No clogging
- Long lifetime
- Cool cut

	TYPE 1 thickness x arbour 1/16" x 7/8"	BOX QTY
4 1/2"	A2180291	50
5"	A2180292	50
6"	A2180293	25
7"	A2180294	25

**BRAINTOOLS**<sup>®</sup>

## XTK8 EXACT

**For steel or stainless steel**

- Ideal for hospital & kitchen equipment manufacturing
- Precise, cool cutting, no discolouration or distortion of the workpiece
- Ideal for thin steel & stainless steel sheets

World's  
Thinnest  
Cutting Wheel!



	TYPE 27 thickness x arbour .032" x 7/8"	BOX QTY
4 1/2"	A2180461	50
5"	A2180462	50



## GAS SAW WHEELS



### FT30 **PROLINE** ●●●

For steel

- Hard robust wheel
- Easy cutting & long life
- External heavy duty reinforcing on both sides

	TYPE 1 arbour 20mm	TYPE 1 arbour 7/8"	TYPE 1 arbour 1"	BOX QTY
12" x 1/8"	A2180601	A2180602	A2180603	25
14" x 3/16"	A2180606	A2180605	A2180604	10

# BLENDING &

## FS1 FUSION

- High stock removal
- No clogging
- Cool grinding



## HEAVY DUTY WHEELS



### FTK33 **PROLINE** ●●●

For steel or stainless steel

- Suitable for solid material, pipes and profiles, hardened steels, or stainless steel alloys
- Tough! A must for heavy applications
- High cutting speed
- Smooth cutting & long life

	TYPE 27 thickness x arbour 3/32" x 7/8"	TYPE 27 thickness x arbour 1/8" x 7/8"	BOX QTY
4 1/2"	A2180544	A2180545	25
5"	A2180546	A2180547	25
6"	.....	A2180540	25
7"	.....	A2180549	25



## CHOP SAW WHEELS



### ST34 **PROLINE** ●●●

For steel or stainless steel

- Quick, easy cutting
- Minimal burr build up
- Designed for chop saws up to 3 H.P.
- Reinforced on both sides

	TYPE 1 thickness x arbour 3/32" x 1"	TYPE 1 thickness x arbour 1/8" x 1"	BOX QTY
12"	A2180701	A2180702	10
14"	A2180703	A2180704	10

# FINISHING The FS1 FUSION

Specially Designed For Grinding Fillet Welds

Combines the long life of a grinding disc with the fine grinding pattern of a flap disc.

### Material

- Rust & acid proofed steels
- High tensile / high alloyed steels
- Hardened steels
- Structural steels
- Tool steels
- Grey cast iron
- Hardox

### Application Examples

- Fillet weld treatment
- Surface grinding
- Burr removing
- Welding seams
- Weld seam preparation

Two different thicknesses to suit your application and **three** grit levels to suit your finishing.



TYPE 27 arbour x 7/8"	40G	60G	80G	BOX QTY
4 1/2" x 3/16"	A3180251	A3180252	A3180253	10
4 1/2" x 1/4"	A3180526	A3180527	A3180528	10
5" x 3/16"	A3180261	A3180262	A3180263	10
5" x 1/4"	A3180536	A3180537	A3180538	10

# XTK35 CROSS THE ORIGINAL XTRA THIN GRINDING & CUTTING

## BRAINTOOLS®

**The XTK35 CROSS delivers extra thin precise cutting and light grinding with one disc**

For steel or stainless steel

- One wheel - **THREE Operations: cuts, light grinds & deburrs**
- Eliminates changing wheels = fewer work interruptions
- Extremely safe due to 3 full layers of fibreglass reinforcing
- Available in 4 1/2" & 5"

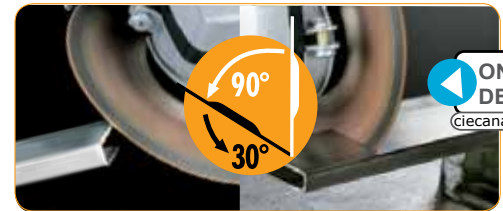

ONLINE DEMO  
ciecanada.com



Three full layers of reinforcing composing the XTK35 Cross guarantees high stability and maximum on the job safety.

TYPE 27 thickness x arbour 5/64" x 7/8"	BOX QTY
4 1/2"	A3180651 25
5"	A3180652 25



**KSM** ALPHA LINE ●●○

**For steel**

- Very aggressive wheel for carbon steel
- Long life with fast metal removal

TYPE 27 thickness x arbour 1/4" x 7/8"		
+	□	BOX QTY
4 1/2"	A1180495	25
5"	A1180497	25
7"	A1180500	10



**RS63** PRO LINE ●●●○

**For steel & stainless steel**

- Extremely long life
- New formulation of bonding & grain mixtures
- Very FAST metal removal

TYPE 27 thickness x arbour 1/4" x 7/8"		
+	□	BOX QTY
4 1/2"	A1180431	25
5"	A1180432	25
7"	A1180434	10



**RS2** PRO LINE ●●●○

**For steel & stainless steel**

- Smooth grinding
- Longer life
- Faster metal removal

TYPE 27 thickness x arbour 1/4" x 7/8"		
+	□	BOX QTY
4 1/2"	A1180507	25
5"	A1180508	25
6"	A1180517	10
7"	A1180509	10

**Grinding Discs**

The hardness of a grinding disc determines its lifetime as well as its stock removal and its stock removing efficiency.

A soft grinding disc is much more aggressive and offers a comfortable grinding behaviour.

A hard grinding disc is characterized by its long lifetime. We recommend hard grinding discs for edge grinding. Soft grinding discs can be used for surface grinding.

Rhodius grinding discs are made in a thickness of 7mm and with a special top layer. Grinding discs, unlike flap discs are characterized by their high stock removal and cutting efficiency as well as lifetime.



**RS24** TOP LINE ●●●●

**For aluminum/  
non-ferrous metals**

- Does not clog or load up
- High stock removal and good life

TYPE 27 thickness x arbour 1/4" x 7/8"		
+	□	BOX QTY
4 1/2"	A1180533	25
5"	A1180536	25
7"	A1180534	10

# FLAP DISCS

Full line catalogue available at [www.ciecanada.com](http://www.ciecanada.com)

**RHODIUS**  
MADE IN GERMANY



## LSZ F VISION

For steel, stainless steel,  
plastic and wood

- Unique to Rhodius
- Cooler grinding reduces heat build up and discolouration

	40G	60G	80G	BOX QTY
4 1/2"	C318016611	C318016711	C318016811	10
5"	C318017111	C318017211	C318017311	10

## BRAINTOOLS®



ONLINE DEMO  
[ciecanada.com](http://ciecanada.com)

LOOK

See through your workpiece!



## LSZ F TOP LINE

For steel, stainless steel,  
plastic and wood

- Longer lasting
- Cool grinding

Also available in flat

	40G	60G	80G	BOX QTY
4 1/2"	C31801852	C31801862	C31801872	10
5"	C31802022	C31802032	C31802042	10
7"	C31801932	C31801942	C31801952	10



## LSZ F3 ALPHA LINE

DON'T LET THE PRICE FOOL YOU!

For steel, stainless steel,  
plastic and wood

- Amazing metal removal
- Extremely long life

	40G	60G	80G	BOX QTY
4 1/2"	C31801668	C31801678	C31801688	10
5"	C31801718	C31801728	C31801738	10



## LSZ F2 ALPHA LINE

UBER VALUE  
For steel, stainless steel,  
plastic and wood

- Optimum angle for maximum metal removal
- Super value

	40G	60G	80G	BOX QTY
4 1/2"	C31801661	C31801671	C31801681	10
5"	C31801711	C31801721	C31801731	10



**SHAFT MOUNTED BRUSHES**

**TWIST KNOT END**

1/4" Shank



	length	wire size	RPM	CARBON
	↔	∅	⊕	☐
3/4"	1 1/4"	.010"	20,000	<b>G1220158</b>
1 1/4"	1 1/4"	.010"	20,000	<b>G1220159</b>

- Durable brush ideal for paint, slag, burr removal, weld seams and spot welds
- The twist knot wire gives this brush an even more aggressive action

	length	wire size	RPM	ST/STEEL
	↔	∅	⊕	☐
3/4"	1 1/4"	.010"	20,000	<b>G1220189</b>
1 1/4"	1 1/4"	.010"	20,000	<b>G1220190</b>

**CRIMPED WIRE END**

1/4" Shank



	length	wire size	RPM	CARBON
	↔	∅	⊕	☐
5/8"	1"	.0118"	18,000	<b>G1220150</b>
3/4"	1"	.0118"	18,000	<b>G1220151</b>

- High resistance wire perfect for frontal applications
- For removal of paint, rust and primer
- Cleaning of moulds and castings

	length	wire size	RPM	ST/STEEL
	↔	∅	⊕	☐
5/8"	1"	.0118"	18,000	<b>G1220185</b>
3/4"	1"	.0118"	20,000	<b>G1220186</b>

**CRIMPED CIRCULAR**

1/4" Shank



	length	wire size	RPM	CARBON
	↔	∅	⊕	☐
1 5/8"	1/2"	.0118"	20,000	<b>G1220160</b>
2"	1/2"	.0118"	20,000	<b>G1220163</b>
3"	5/8"	.0118"	12,000	<b>G1220165</b>

- For surface preparation for hard to reach areas
- Light deburring and removal of corrosion and paint
- Used for trimming of casting joints and rubber to metal bonded parts

	length	wire size	RPM	ST/STEEL
	↔	∅	⊕	☐
2"	1/2"	.0118"	20,000	<b>G1220193</b>
3"	5/8"	.0118"	12,000	<b>G1220196</b>

**Designed for tough demanding applications**

Material:

- Steel
- Stainless Steel
- Non-ferrous metals

Application:

- Rust/ scale removal
- Weld spatter
- Deburring
- Cleaning castings/ forgings

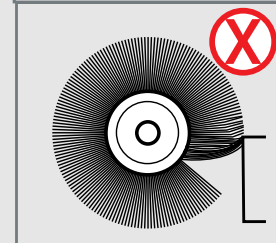
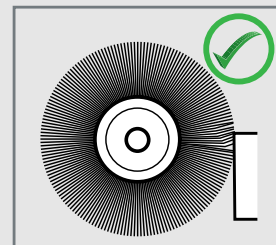

**PROFLEXX**

Wire brushes are used in many industries including: Pipeline construction, foundries, ship building, oil and gas industries and construction. These brushes are available in either **Carbon Steel** wire or **Stainless Steel** wire.





# WIRE WHEEL BRUSHES

## TWIST KNOT BEVEL BRUSH

5/8-11 arbour



wire size			RPM	CARBON
+	Ø	(RPM)		
4"	.015"	20,000	G1220110	
5"	.020"	15,000	G1220111	

- Simply incredible for tough applications including paint, scale and corrosion
- Angle brush for hard to reach areas - edges, corners and internal corners
- Providing the convenience of both a cup and wire brush

wire size			RPM	ST/STEEL
+	Ø	(RPM)		
4"	.015"	20,000	G1220133	
5"	.020"	15,000	G1220134	

## TWIST KNOT WHEEL 2-3 times the life of the competition

5/8-11 arbour



wire size			RPM	CARBON
+	Ø	(RPM)		
4 1/2"	.020"	15,000	G1220008	
5"	.020"	15,000	G1220014	
6"	.020"	10,000	G1220013	

- Excels on large diameter pipe for cleaning of root and cap welds
- Removing residues of adhesive, hard scale rust and paint
- Extra long life, heavy duty construction

wire size			RPM	ST/STEEL
+	Ø	(RPM)		
4 1/2"	.020"	15,000	G1220027	
5"	.020"	15,000	G1220033	
6"	.020"	10,000	G1220032	

## STRINGER BEAD

5/8-11 arbour



wire size			RPM	CARBON
+	Ø	(RPM)		
4 1/2"	.020"	15,000	G1220006	
5"	.020"	12,000	G1220011	
6"	.020"	10,000	G1220010	

- Designed for narrow root passes and restricted access applications
- Heavy duty construction gives extra long life

wire size			RPM	ST/STEEL
+	Ø	(RPM)		
4 1/2"	.020"	15,000	G1220025	
5"	.020"	15,000	G1220019	
6"	.020"	10,000	G1220030	

## CUP BRUSHES

### CRIMPED WIRE CUP

5/8-11 arbour



wire size			RPM	CARBON
+	Ø	(RPM)		
3"	.012"	12,500	G1220051	

- For light removal of paint, rust, etc.
- No aggressive scoring of the workpiece

wire size			RPM	ST/STEEL
+	Ø	(RPM)		
3"	.012"	12,500	G1220081	

### TWIST KNOT CUP

5/8-11 arbour



wire size			RPM	CARBON
+	Ø	(RPM)		
3"	.020"	12,500	G1220041	

- Heavy duty removal of rust, paint, weld splatter, etc.
- Tight twist gives extra long life

wire size			RPM	ST/STEEL
+	Ø	(RPM)		
3"	.020"	12,500	G1220062	

### TWIST KNOT BRIDLED CUP

5/8-11 arbour



wire size			RPM	CARBON
+	Ø	(RPM)		
3"	.020"	12,500	G1220091	
4"	.020"	8,500	G1220093	

- Tight twist and bridle gives aggressive action for removal of heavy spatter, rust, etc.
- The support ring of the special design prevents excessive spreading of the fill material
- When worn down simply "knock off" the bridle to expose more brush length

wire size			RPM	ST/STEEL
+	Ø	(RPM)		
3"	.020"	12,500	G1220102	
4"	.020"	8,500	G1220104	

## autoCROSS 3 KIT



Includes hardshell transport case to protect unit

### PULSED SELF-LEVELLING CROSSLINE LASER

- Self levelling crossline laser
- Horizontal and vertical lines can be switched on separately
- Take unit out of self-levelling mode and lock line in place allowing to set unit in any angle
- Accuracy 3mm/10m (.12"/ 32')
- Indoor/outdoor range with **optional** receiver 30 m (100')



L2654KLPP

## uniLASER AHV KIT



### SELF LEVELLING CONSTRUCTION LASER

- For horizontal and vertical applications with plumb beams up and down
- Indoor/outdoor range with receiver 300 m (1000 ft)
- Accuracy 3mm/30m (.12"/ 98')
- Battery life 20 hours
- Complete set with receiver and remote control in a stable plastic storage and transport case



L2654808AHV SET K3

## autoMAGIC



### CROSSLINE AND 5 BEAM LASER ALL IN ONE

- Self levelling mechanism
- Automatic out-of-level sensing
- No beam shaking when bumped
- 5 laser beams at a time
- Indoor/outdoor range with **optional** receiver 50 m (150')
- Accuracy 3mm/10m (.12"/ 32')



L2654KLP5SP

## NAUTILUS IPX7



Includes carrying bag



### SELF LEVELLING WATERPROOF

- Horizontal operation
- Indoor/outdoor range with receiver 500 m (1500')
- Accuracy 2.6mm/30m (0.1"/ 98')
- Battery life 50 hours
- Robust aluminum casing
- Shock protection



L264803AHSET

## topoMAT IPX5

Includes robust carrying case and inclinometer



Lockable 90° tilting joint



### SELF LEVELLING/ONE PERSON OPERATION

- **Rainproof**
- Automatic laser-stop function in case of change in position
- Horizontal/vertical operation remote control
- Indoor/outdoor range with receiver 500 m (1500')
- Accuracy 2.6mm/30m (0.1"/ 98')
- Battery life 70 hours
- Shock protection



L264802NSET

# TAPE MEASURES

Full line catalogue available at [www.ciecanada.com](http://www.ciecanada.com)

## RADIUS case



mm/inch

### LARGE CRANK ARM AND PARK POSITION

- Easy grip soft touch surface
- Slide bearing shells for highest winding comfort

#### Radius Case White Enamelled

20m	L3501215020 BHF
30m	L3501225030 BHF

#### Radius Case Isolan

20m	L3505225020 BHF
30m	L3505235030 BHF

## BASIC frame



Frame style varies according to order number

mm/inch



### HIGH IMPACT PLASTIC FRAME

- Flextop prevents the notorious breakage of the highly stressed first 10cm of the tape

#### Basic Frame White Enamelled

30m	L3501315030 BHF
50m	L3501335050 BHF
100m	L3501345100 BHF

#### Basic Frame Isolan

30m	L3505325030 BHF
50m	L3505345050 BHF

## ERGOLINE frame



Frame style varies according to order number

mm/inch



### BALL BEARINGS FOR HIGHEST WINDING CONVENIENCE

- Park position for crank arm and tape commencement ring
- Ergonomically shaped frame with easy to grip, soft rubber protrusions

#### Ergoline Frame White Enamelled

30m	L3301025030 BHF
50m	L3301035050 BHF

#### Ergoline Frame Isolan

30m	L3305035030 BHF
50m	L3305045050 BHF



SCRATCH RESISTANT



### White Enamelled

Concave, tempered springblade steel with anti-corrosive phosphate coating



### Isolan

Carbon steel Yellow synthetic resin, polyamide coating



**FLEXTOP** tip made of transparent, highly flexible plastic, reliably prevents breakage at the tape commencements.



For all steel measuring tapes 13mm, pull ring made of break-proof plastic, 2 notches for weights.



**BHF:** Hooking with FLEXTOP tip, measurement commencement B.

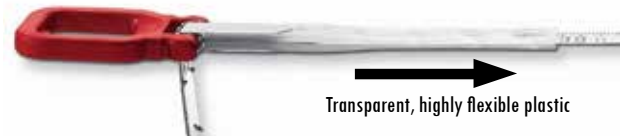

Transparent, highly flexible plastic

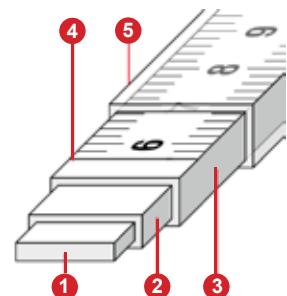

### TAPE STRUCTURE

1. Concaved, tempered spring blade steel of high stability
2. Anti-corrosive phosphate coating
3. Synthetic resin, stoved
4. Printed graduation with red meter figures
5. Clear varnish to protect against wear, stoved

## WINKELSTAR MULTIPLE ANGLE SQUARE

- Foldable multiple angle square can be adjusted between 0° and 270°
- Angles can be fixed in 15° steps.
- Built-in vials enable it to be used as a spirit level.
- Easy to transport.

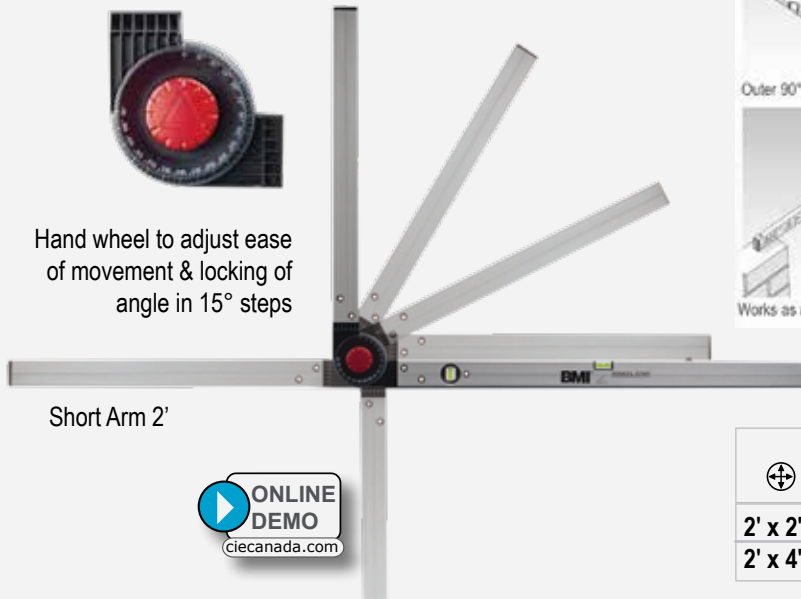
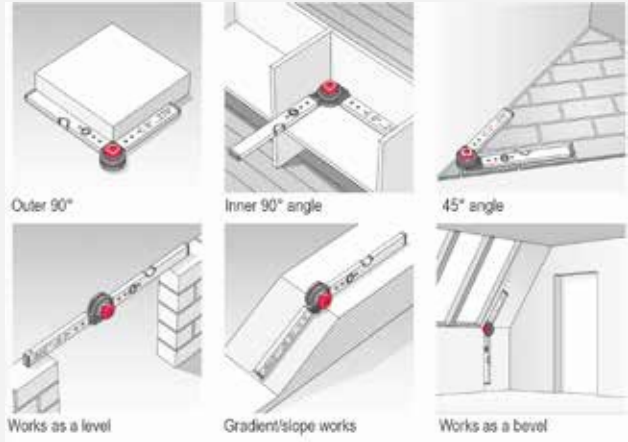

MAGNETIC	
+	Ⓜ
2' x 2'6"	L171506080M
2' x 4'	L1715060120M

NON MAGNETIC	
+	Ⓜ
2' x 2'6"	L171506080
2' x 4'	L1715060120

## TRAPEZOID TORPEDO

### GREAT FOR ALL CONSTRUCTION TRADES

- 2 vials
- Heavy weight, very high torsion-resistance trapezoid shaped aluminum die cast level
- Red powder-coated body
- Measuring accuracy 1.0 mm/m normal position

MAGNETIC	
+	Ⓜ
12"	L1689030TM



## TORPEDO

### IDEAL FOR DRYWALL, CONSTRUCTION AND SCAFFOLD ERECTION

- Top end vial excellent for vertical measurements
- 2 Ultrasonic welded vials (magnifying)
- Highly accurate inverted measurement 0.5mm/m



Vial with **MAGNIFYING** effect means No more double bubble trouble



NON MAGNETIC	
+	Ⓜ
8"	L1692020

MAGNETIC	
+	Ⓜ
8"	L1692020M
10"	L1692025M

# SPIRIT LEVELS

Full line catalogue available at [www.ciecanada.com](http://www.ciecanada.com)



## EUROSTAR

### BEST SUITED FOR PIPING, FITTING, PLUMBING, CONCRETE AND CERAMIC INSTALLATION

- Sturdy box design 2" x 3/4" with 1/16" wall thickness
- 2 % slope markings ideal for plumbing, concrete and ceramic installations
- Laser marked vials provide 0.5mm/m accuracy for a lifetime
- Reflection free vials, no more double bubble trouble



MAGNETIC	
⊕	⊖
2'	L1690060EM
4'	L1690120EM
6'	L1690180EM

NON MAGNETIC	
⊕	⊖
2'	L1690060E
4'	L1690120E
6'	L1690180E

## ROBUST

### DESIGNED FOR THE JOB SITE, ALL CONSTRUCTION APPLICATIONS AND RENOVATION PROJECTS

- EXTRA STRONG 4 chamber profile - 2mm thick a must for the professional
- Original BMI crescent shaped vial with magnifying effect in regular or inverted position
- Highest accuracy for life due to BMI patented ultrasonically welded vials

Vial with crescent shape to ensure .05mm/m accuracy in inverted position



◆ Models containing the letter D have hand holes

MAGNETIC	
⊕	⊖
2'	L1698060M
4'	L1698120DM
6'	L1698180DM

NON MAGNETIC	
⊕	⊖
2'	L1698060
4'	L1698120D
6'	L1698180D

## MASONS FRIEND



### TOUGH 4 CHAMBER PROFILE - 2mm thick

- 2 stainless steel strips (1 with graduation)
- Ultrasonically welded vials (magnifying)
- Accuracy 0.5mm/m in normal or inverted position
- Black anodized

Vial with crescent shape to ensure .05mm/m accuracy in inverted position



NON MAGNETIC	
⊕	⊖
4'	L1698120E

**Standard Quality**

**APPLICATION**

- Heavy duty sanding
- Weld removal
- Sheet metal
- Steel plates

**Steel**

- Special aluminum oxide full resin fibre discs
- Excels in a wide variety of applications
- No harmful additives for a safer working environment

**AFR**



For steel, cast iron and structural steel

**4 1/2" x 7/8" ⊕**

		BOX QTY
C1185201	<b>24G</b>	25
C1185202	<b>36G</b>	25
C1185204	<b>50G</b>	25
C1185205	<b>60G</b>	25
C1185206	<b>80G</b>	25
C1185207	<b>100G</b>	25
C1185208	<b>120G</b>	25

**5" x 7/8" ⊕**

		BOX QTY
C1185221	<b>24G</b>	25
C1185222	<b>36G</b>	25
C1185224	<b>50G</b>	25
C1185225	<b>60G</b>	25
C1185226	<b>80G</b>	25
C1185227	<b>100G</b>	25
C1185228	<b>120G</b>	25

**7" x 7/8" ⊕**

		BOX QTY
C1185241	<b>24G</b>	25
C1185242	<b>36G</b>	25
C1185244	<b>50G</b>	25
C1185245	<b>60G</b>	25
C1185246	<b>80G</b>	25
C1185247	<b>100G</b>	25
C1185248	<b>120G</b>	25

**High Performance**

**APPLICATION**

- Heavy duty sanding
- Weld removal
- Sheet metal
- Steel plates
- Edge deburring

**Steel / Stainless Steel**

- Zirconia full resin bonded fibre discs
- Sharpens itself in use
- Cool grinding action reduces glazing and loading

**ZFR**



For steel, stainless steel, cast iron and structural steel

**4 1/2" x 7/8" ⊕**

		BOX QTY
C1185351	<b>24G</b>	25
C1185352	<b>36G</b>	25
C1185354	<b>50G</b>	25
C1185355	<b>60G</b>	25
C1185356	<b>80G</b>	25

**5" x 7/8" ⊕**

		BOX QTY
C1185361	<b>24G</b>	25
C1185362	<b>36G</b>	25
C1185364	<b>50G</b>	25
C1185365	<b>60G</b>	25
C1185366	<b>80G</b>	25

**7" x 7/8" ⊕**

		BOX QTY
C1185371	<b>24G</b>	25
C1185372	<b>36G</b>	25
C1185374	<b>50G</b>	25
C1185375	<b>60G</b>	25
C1185376	<b>80G</b>	25

**FLEXIBLE**



**ADVANTAGES**

- High quality backing pad
- Suitable for heavy duty use
- Flexible
- Extremely wear resistant

For steel, stainless steel & non-ferrous metals

⊕	ARBOUR	Ⓜ
4 1/2"	5/8-11"	C2180904
5"	5/8-11"	C2180906
7"	5/8-11"	C2180908

**BACKING PADS**



**TURBO**

**ADVANTAGES**

- Heavy duty back pad
- Extra cooling ribs and air vents provide cooling action
- Air flow cooling action extends life of the disc
- Especially effective on stainless steel and alloys

For steel, stainless steel & non-ferrous metals

⊕	ARBOUR	Ⓜ
4 1/2"	5/8-11"	C2180951
5"	5/8-11"	C2180953
7"	5/8-11"	C2180955

# CLAMPS

Full line catalogue available at [www.ciecanada.com](http://www.ciecanada.com)

**TURNUS**  
MADE IN GERMANY



*The market leader for:  
All steel screw clamps,  
hand vises,  
heavy duty clamps  
and more!*



REPLACEABLE  
PRO PAD  
tilts < 35°

## ALL STEEL FITTER CLAMPS

### MEDIUM DUTY FITTER'S CLAMP

OPENING	THROAT	CLAMPING PRESSURE	
8"	4 3/4"	1800 lb	J3473020
10"	4 3/4"	1800 lb	J3473025
12"	4 3/4"	1800 lb	J3473030
16"	4 3/4"	1800 lb	J3473040
20"	4 3/4"	1800 lb	J3473050
24"	4 3/4"	1800 lb	J3473060

### HEAVY DUTY FITTER'S CLAMP

OPENING	THROAT	CLAMPING PRESSURE	
10"	4 3/4"	2660 lb	J3475025
12"	5 1/2"	2660 lb	J3475030
20"	5 1/2"	2660 lb	J3475050
31"	5 1/2"	2660 lb	J3475080
40"	4 3/4"	2660 lb	J3475100
50"	4 3/4"	2660 lb	J3475125
60"	4 3/4"	2660 lb	J3475150

### EXTRA HEAVY DUTY FITTER'S CLAMP

OPENING	THROAT	CLAMPING PRESSURE	
12"	7"	4880 lb	J3480030
16"	7"	4880 lb	J3480040
20"	7"	4880 lb	J3480050
24"	7"	4880 lb	J3480060
31"	7"	4880 lb	J3480080
40"	7"	4800 lb	J3480100



Check out our line of  
**KUKKO Pullers** →  
on our website  
[www.ciecanada.com](http://www.ciecanada.com)



### KEY FEATURES INCLUDE

- LOCKING HANDLE
- SPECIAL PRESSURE PAD  
Screw-on type, tilts < 35°,  
gun metal finish, easily replaceable
- ECONOMICAL
- DROP-FORGED, HEAT TREATED  
GALVANIZED SLIDING ARM

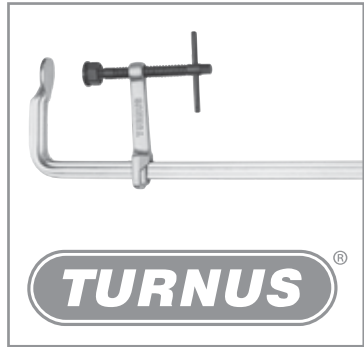
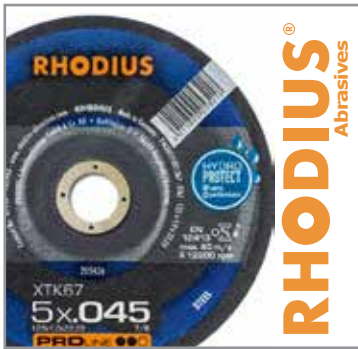

[www.ciecanada.com](http://www.ciecanada.com)